

Pseudo Derivative Feedback current controlled sensorless PMSM drive with Flux-Torque based MRAS estimator for low speed operation

Karthikeyan A^{1,*}, Prabhakaran K K¹, Venkatesa Perumal B¹, Nagamani C²

¹Department of Electrical and Electronics Engineering, National Institute of Technology Karnataka, Surathkal

²Department of Electrical and Electronics Engineering, National Institute of Technology, Tiruchirappalli

*jakarthik@nitk.edu.in

Abstract — In this paper, a simple and robust speed estimator and Pseudo Derivative Feedback (PDF-PDF) controller are proposed for sensorless PMSM drive to improve its performance at standstill and low speed regions. The speed estimator is formed using stator flux and electromagnetic torque based model reference adaptive system, which performs better during transient conditions and reduces steady state error for wide rotor speed variations which includes low speed regions. The proposed PDF-PDF controller reduces the overshoot and improves settling time of the system. The stability of the proposed estimator is verified through small signal model and the machine parameter sensitivity is also analyzed. The performance of the proposed estimator and controller is validated by considering variation in the low speed regions which includes standstill condition. The simulations are carried out through MATLAB/Simulink and it is also experimentally verified through FPGA controller based 1.2hp laboratory prototype PMSM drive. It is found that the maximum estimated rotor speed and position error are ± 2 rad/s and $\pm 1^\circ$ respectively during low speed operation at transient and steady state conditions.

Keywords: *permanent magnet synchronous motor (PMSM), model reference adaptive system (MRAS), sensorless speed and position estimation, field oriented control (FOC).*

I. INTRODUCTION

In recent years, PMSM drives are the first choice in industrial applications and home appliances such as fans, air conditioners, washing machines and dishwashers. The field oriented control of PMSM drive [1] has widely used due to its high dynamic performance. FOC scheme requires the rotor speed and position information. Therefore, sensorless rotor speed and position estimation is preferred, because of reduced hardware complexity, greater reliability and lower cost. Sensorless rotor speed and position estimation methods are broadly classified as: fundamental excitation schemes, saliency and signal injection methods. The fundamental excitation schemes can be classified state observer based methods and MRAS based methods. State observer based methods are further classified into: stator flux based observer methods [2-3], sliding mode observer methods [4-5], Extended Kalman filter method [6]. Observer based methods, require proper initialization and knowledge of machine parameters. At low speed regions, the performance of speed and position estimation is affected by integrated drift problem. Though sliding mode observer and Extended Kalman filter methods perform well at low speed operation, they suffer from

chattering phenomenon and high computational complexity. MRAS based methods discussed in [7-10] for rotor speed and position estimation. MRAS speed and position estimators based on stator flux, stator current and reactive power have been investigated for field oriented control of PMSM drive. The main drawback of these techniques is machine parameter sensitivity which constraints its performance at standstill and low speed regions. Speed loop pseudo derivative feedback (PDF) controller for the speed control of PMSM drive is proposed in [11], where this technique eliminates overshoot in the rotor speed but it does not eliminates overshoot in the stator current. To achieve robust performance, it is necessary to design proper current controller for PMSM drive. PDF current control for the three phase grid connected inverter [12], improves transient performance of grid current and eliminates overshoot and oscillation of the system.

In this paper, flux-torque based MRAS speed estimator with PDF-PDF controller is proposed to improve the robustness of speed and position estimation as well as system dynamic response with respect to low speed and standstill operation. This paper is organized as follows, the flux-torque based MRAS estimator, structure of PDF-PDF control, in section 2. Stability and sensitivity analysis of the proposed estimator are explained in section 3 Simulation and experimental results are demonstrated in section 4 and 5.

II. FLUX-TORQUE BASED MRAS ESTIMATOR

In this paper, the rotor speed and position are estimated by differences in stator flux and electromagnetic torque. Real system is considered as reference model and it is independent with respect to estimated quantity which provides ψ_{ds} and ψ_{qs} . The mathematical flux model is considered as the adjustable model and it includes estimated quantity, which provides $\hat{\psi}_{ds}$ and $\hat{\psi}_{qs}$. The first error signal is obtained from comparing reference and estimated stator flux and it is processed through the PI controller. The second error signal is obtained from comparing reference and estimated electromagnetic torque. The sum of the stator flux and electromagnetic torque error signal are used to estimate the rotor speed.

The stator d - q voltages are expressed as [11]

$$v_{qs} = R_s i_{qs} + \omega_r \psi_{ds} + p \psi_{qs} \quad (1)$$

$$v_{ds} = R_s i_{ds} - \omega_r \psi_{qs} + p \psi_{ds} \quad (2)$$

Stator current can be expressed as

$$i_{ds} = (\psi_{ds} - \psi_m) / L_d \quad (3)$$

$$i_{qs} = \psi_{qs} / L_q \quad (4)$$

by substituting (3) and (4) in (1) and (2), the stator flux can be written in matrix form as given

$$\frac{d}{dt} \begin{bmatrix} \psi_{ds} \\ \psi_{qs} \end{bmatrix} = \begin{bmatrix} -\frac{R_s}{L_d} & \omega_r \\ -\omega_r & -\frac{R_s}{L_q} \end{bmatrix} \begin{bmatrix} \psi_{ds} \\ \psi_{qs} \end{bmatrix} + \begin{bmatrix} 1 & 0 \\ 0 & 1 \end{bmatrix} \begin{bmatrix} V_{ds} + \frac{\psi_m R_s}{L_d} \\ V_{qs} \end{bmatrix} \quad (5)$$

The above (5) is considered as reference model, which is further simplified and given as below

$$\dot{\psi} = A\psi + Bu \quad (6)$$

$$\psi = C\psi \quad (7)$$

where

$$A = \begin{bmatrix} -\frac{R_s}{L_d} & \omega_r \\ -\omega_r & -\frac{R_s}{L_q} \end{bmatrix}, \psi = [\psi_{ds} \quad \psi_{qs}]^T, B = C = \begin{bmatrix} 1 & 0 \\ 0 & 1 \end{bmatrix}, u = \begin{bmatrix} V_{ds} + \frac{\psi_m R_s}{L_d} \\ V_{qs} \end{bmatrix}$$

In (6) the parameters stator flux and rotor speed are replaced with estimated quantities which forms adjustable model and given as

$$\dot{\hat{\psi}} = \hat{A}\hat{\psi} + Bu \quad (8)$$

$$\hat{\psi} = C\hat{\psi} \quad (9)$$

where

$$\hat{A} = \begin{bmatrix} -R_s/L_d & \hat{\omega}_r \\ -\hat{\omega}_r & -R_s/L_q \end{bmatrix}, \hat{\psi} = [\hat{\psi}_{ds} \quad \hat{\psi}_{qs}]^T$$

The stator flux error is obtained from the cross product between reference model and adjustable model outputs (i.e. reference stator flux and estimated stator flux).

$$e_\psi = \psi_s \otimes \hat{\psi}_s = (\hat{\psi}_{ds}\psi_{qs} - \psi_{ds}\hat{\psi}_{qs}) \quad (10)$$

In the conventional stator flux based MRAS speed and position estimator [9], the rotor speed and position are estimated from the difference between reference and estimated stator flux. In (6), the stator flux estimator has open loop integral function, which introduces drift from the original value during low speed regions because stator is excited with low frequency voltages. Hence the performance of the classical estimator is not satisfactory at low speed regions. In order to improve the performances at low speed regions, in the proposed study the electromagnetic torque error is added in the rotor speed and position estimator. The calculation of electromagnetic torque error is as follows

$$T_e = (3/2)(P/2)(\psi_{ds}i_{qs} - \psi_{qs}i_{ds}) \quad (11)$$

similarly, the estimated electromagnetic torque is calculated using (9) and given as

$$\hat{T}_e = (3/2)(P/2)(\hat{\psi}_{ds}\hat{i}_{qs} - \hat{\psi}_{qs}\hat{i}_{ds}) \quad (12)$$

Mechanical dynamics of the PMSM can be expressed as

$$T_e - T_l = J \frac{d\omega_r}{dt} \quad (13)$$

Now, the mechanical dynamics of the PMSM is given in (13), in that any change in load torque which introduces variation in the rotor speed until both the torques i.e. load torque and electromagnetic torque are equal. Similarly any change in the load torque, introduces a variation in the estimated rotor speed till the estimated electromagnetic torque is equal to load torque. So in (13), the rotor speed and electromagnetic torque are replaced by their estimated values and expressed as

$$\hat{T}_e - T_l = J \frac{d\hat{\omega}_r}{dt} \quad (14)$$

By subtracting (14) from (13), the electromagnetic error is obtained

$$e_T = T_e - \hat{T}_e = J \frac{d(\omega_r - \hat{\omega}_r)}{dt} \quad (15)$$

where T_e and \hat{T}_e are given by (11) and (12)

Finally, the estimated rotor speed is obtained using stator flux and electromagnetic torque error which is given below

$$\hat{\omega}_r = \int_0^t k_1 (e_\psi) dt + k_2 (e_T) + e_T \quad (16)$$

where $k_1, k_2 \geq 0$

In (16), electromagnetic torque error is added to improve the robustness of estimator thereby it performs well at standstill, low speed regions and also with respect to machine parameter variations. Further it does not involve computation of back-EMF and programmable low-pass filters.

The estimated rotor position is achieved by integrating the estimated speed.

$$\hat{\theta} = \int \hat{\omega}_r dt \quad (17)$$

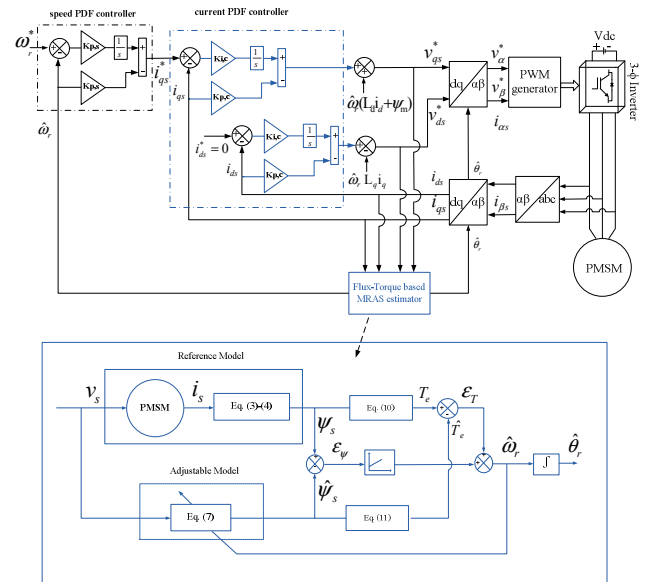

Fig. 1. Block diagram of PDF-PDF controller with flux-based torque MRAS estimator for sensorless PMSM drive

Fig.1 shows the flux and torque based MRAS estimator and PDF controller for the sensorless speed control of permanent magnet synchronous motor drive. The controller involves a PDF based speed (outer) and current (inner) loop. The proposed PDF-PDF controller reduces the overshoot and has fast transient response for the overall system where as flux-torque based MRAS estimator improves robustness with respect to motor parametric variations at low speed which includes standstill condition.

III. STABILITY ANALYSIS OF THE FLUX-TORQUE BASED MRAS ESTIMATOR

To validate the dynamic response of the flux-torque based MRAS estimator stability analysis is performed by linearizing the stator flux equation (6) and (7) around a stable point ψ_{s0} , which is as follows:

$$\Delta \dot{\psi} = A\Delta\psi + \Delta A\psi_0 \quad (18)$$

$$\Delta \psi = C\Delta\psi \quad (19)$$

$$\Delta \psi = C(sI - A)^{-1} \Delta A\psi_0 \quad (20)$$

where $x_0 = [\psi_{sd0} \ \psi_{sq0}]^T$

now consider small variation in speed, then ΔA can be expressed as

$$\Delta A = \begin{bmatrix} 0 & 1 \\ -1 & 0 \end{bmatrix} \Delta\omega_r \quad (21)$$

by substituting (21) into (20), the $\Delta\psi$ can be expressed as

$$\begin{bmatrix} \Delta\psi_{sd} \\ \Delta\psi_{sq} \end{bmatrix} = \begin{bmatrix} 1 & 0 \\ 0 & 1 \end{bmatrix} (sI - A)^{-1} \begin{bmatrix} 0 & 1 \\ -1 & 0 \end{bmatrix} \Delta\omega_r \begin{bmatrix} \psi_{sd0} \\ \psi_{sq0} \end{bmatrix} \quad (22)$$

By linearizing the stator flux error (10) and dividing by $\Delta\omega_r$ yields the transfer function between $\Delta\epsilon_\psi$ and $\Delta\omega_r$,

$$\frac{\Delta\epsilon_\psi}{\Delta\omega_r} = \frac{\Delta\psi_{ds} * \psi_{qso} - \Delta\psi_{qs} * \psi_{dso}}{\Delta\omega_r} \quad (23)$$

Substituting (23) in (22), the stator flux error transfer function can be expressed as

$$\frac{\Delta\epsilon_\psi}{\Delta\omega_r} = \frac{\psi_{qso} * [-\hat{\omega}_r \psi_{dso} + (s + R_s/L_q) \psi_{qso}] + \psi_{dso} [(s + R_s/L_d) \psi_{dso} + \hat{\omega}_r \psi_{qso}]}{(s + R_s/L_q) * (s + R_s/L_d) + \hat{\omega}_r^2} = G(s) \quad (24)$$

In the proposed estimator the electromagnetic torque error is added to improve the performance in the low speed region for PMSM drive and from (15) electromagnetic torque error is expressed as

$$\epsilon_T = T_e - \hat{T}_e = J \frac{d\Delta\omega_r}{dt} \quad (25)$$

finally, the closed loop transfer function of proposed MRAS speed estimator is given as

$$\frac{\omega_r}{\hat{\omega}_r} = \frac{G(s)(K_{pMRAS} + \frac{K_{iMRAS}}{s}) + Js}{1 + G(s)(K_{pMRAS} + \frac{K_{iMRAS}}{s}) + Js} \quad (26)$$

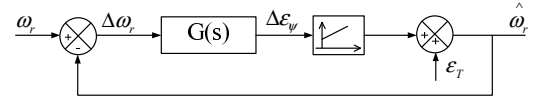

Fig. 2. Closed loop representation of Flux-Torque based MRAS estimator

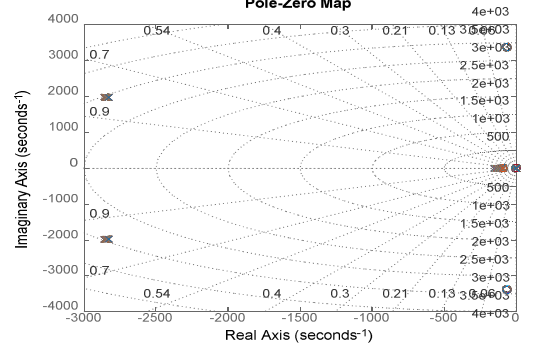

Fig. 3. Pole loci for the closed loop transfer function of Flux-Torque based MRAS estimator. $\hat{\omega}_r = 0 \rightarrow \pm 356$ elec. rad/s.

Fig. 2 shows the closed loop representation of proposed Flux-Torque based MRAS estimator. The stability of the estimator is analyzed through pole placement for the closed loop transfer function of flux-torque based MRAS estimator. Fig 3 shows loci of the closed loop poles and zeros for the rated speed range ($\hat{\omega}_r = 0 \rightarrow \pm 356$ elec. rad/s). It is observed from fig. 3 that all the poles are located in the left hand side of the s plane and it shows the proposed estimator is stable for motoring with speed reversal operation for the entire operating range (-360 to +360 elec. rad/s).

3.1 Parameter sensitivity analysis for the Flux-Torque based MRAS estimator

To validate the robustness of flux-torque based MRAS estimator the parameter sensitivity analysis is carried out. Because machine parameters are involved in the estimation algorithm and due to ageing effect, incorrect estimation of machine parameters such as stator resistance, inductance and rotor flux results variation in estimation of rotor speed and position. The machine dynamic expression involves stator flux and incorrect computation of stator flux leads to incorrect computation of electromagnetic torque thereby affects the estimation of rotor speed and position. So in this analysis stator flux is considered and any mismatch in stator flux can be computed by considering the mismatch in stator resistance, $d-q$ axes inductance and rotor flux.

The estimated stator flux can be expressed as

$$\dot{\hat{\psi}}_{ds} + k_1 \hat{\psi}_{ds} - k_1 \psi_m - \hat{\omega}_r \hat{\psi}_{qs} = V_{ds} \quad (27)$$

$$\dot{\hat{\psi}}_{qs} + \hat{\omega}_r \hat{\psi}_{ds} + k_2 \hat{\psi}_{qs} = V_{qs}$$

where $k_1 = R_s/L_d, k_2 = R_s/L_q$

(27) is modified by rearranging the $\hat{\psi}_{ds}$ and $\hat{\psi}_{qs}$ terms and rewritten as

$$\dot{\hat{\psi}}_{ds} + k_1 \hat{\psi}_{ds} = V_{ds} + \hat{\omega}_r \hat{\psi}_{qs} + k_1 \psi_m \quad (28)$$

$$\dot{\hat{\psi}}_{qs} + k_2 \hat{\psi}_{qs} = V_{qs} - \hat{\omega}_r \hat{\psi}_{ds}$$

by solving (28) using integral factor, $\hat{\psi}_{ds}$ and $\hat{\psi}_{qs}$ can be computed as

$$\hat{\psi}_{ds} e^{k_1 t} = \frac{(V_{ds} + \hat{\omega}_r \hat{\psi}_{qs} + k_1 \psi_m)}{k_1} (e^{k_1 t} - 1) \quad (29)$$

$$\hat{\psi}_{ds} = \frac{(V_{ds} + \hat{\omega}_r \hat{\psi}_{qs} + k_1 \psi_m)}{k_1} (1 - e^{-k_1 t}) \quad (30)$$

$$\hat{\psi}_{qs} e^{k_2 t} = \frac{(V_{qs} - \hat{\omega}_r \hat{\psi}_{ds})}{k_2} (e^{k_2 t} - 1) \quad (31)$$

$$\hat{\psi}_{qs} = \left\{ \frac{V_{qs}}{k_2} - \frac{\hat{\omega}_r \hat{\psi}_{ds}}{k_2} \right\} (1 - e^{-k_2 t}) \quad (32)$$

now variation in the q - d axes stator flux is computed by variation in stator resistance R_s i.e. k_1 , k_2 then

$$\begin{aligned} \Delta \hat{\psi}_{ds} = & \psi_m t e^{-k_1 t} \Delta k_1 + \frac{(V_{ds} + \hat{\omega}_r \hat{\psi}_{qs})}{k_1} (e^{-k_1 t} - 1) \frac{\Delta k_1}{k_1^2} \\ & + (V_{ds} + \hat{\omega}_r \hat{\psi}_{qs}) t \left(\frac{\Delta k_1}{k_1 e^{k_1 t}} \right) \end{aligned} \quad (33)$$

$$\begin{aligned} \Delta \hat{\psi}_{qs} = & (V_{qs} - \hat{\omega}_r \hat{\psi}_{ds}) (e^{-k_2 t} - 1) \left(\frac{\Delta k_2}{k_2^2} \right) + \\ & \frac{(V_{qs} - \hat{\omega}_r \hat{\psi}_{ds})}{k_2} t \left(\frac{\Delta k_2}{k_2 e^{k_2 t}} \right) \end{aligned} \quad (34)$$

by considering variation in the q axes inductance alone in (32), result in $\Delta k_2 \neq 0$ and $\Delta k_1 = 0$, $\Delta \hat{\psi}_{ds} = 0$ then

$$\begin{aligned} \Delta \hat{\psi}_{qs} = & (V_{qs} - \hat{\omega}_r \hat{\psi}_{ds}) (e^{-k_2 t} - 1) \left(\frac{\Delta k_2}{k_2^2} \right) + \\ & \frac{(V_{qs} - \hat{\omega}_r \hat{\psi}_{ds})}{k_2} t \left(\frac{\Delta k_2}{k_2 e^{k_2 t}} \right) \end{aligned} \quad (35)$$

similarly in (30) considering variation in the d axes inductance alone, result in $\Delta k_1 \neq 0$ and $\Delta k_2 = 0$, $\Delta \hat{\psi}_{qs} = 0$ then

$$\begin{aligned} \Delta \hat{\psi}_{ds} = & \psi_m t e^{-k_1 t} \Delta k_1 + \frac{(V_{ds} + \hat{\omega}_r \hat{\psi}_{qs})}{k_1} (e^{-k_1 t} - 1) \frac{\Delta k_1}{k_1^2} \\ & + (V_{ds} + \hat{\omega}_r \hat{\psi}_{qs}) t \left(\frac{\Delta k_1}{k_1 e^{k_1 t}} \right) \end{aligned} \quad (36)$$

Finally, the variation in the ψ_m alone in (30), result in $\Delta k_1 \neq 0$ and $\Delta k_2 = 0$, $\Delta \hat{\psi}_{qs} = 0$ then

$$\Delta \hat{\psi}_{ds} = (1 - e^{-k_1 t}) \Delta \psi_m \quad (37)$$

To summarize above analysis, in (33)-(36), $\Delta k_1 \ll k_1^2$, $\Delta k_1 \ll k_1 e^{k_1 t}$, $\Delta k_2 \ll k_2^2$ and $\Delta k_2 \ll k_2 e^{k_2 t}$ hence the variation in the $\Delta \hat{\psi}_{qs}$ and $\Delta \hat{\psi}_{ds}$ is very small. From (33)-(37), It is observed that the flux-torque based MRAS estimator is not affected by the variation in the stator resistance (R_s), d - q axes stator inductance (L_q , L_d) and permanent magnet flux link-

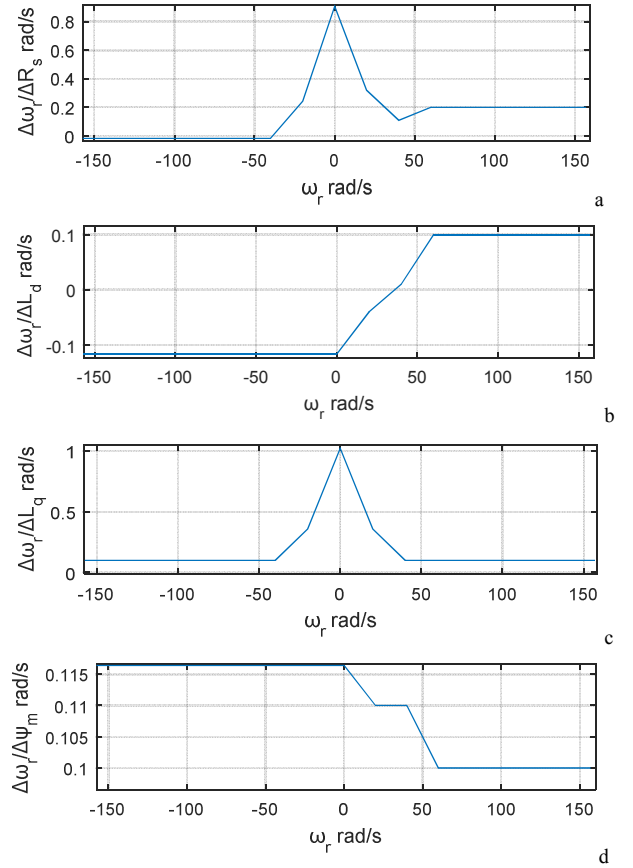

Fig.4. Sensitivity plot for the proposed estimator with respect to variation in the R_s , L_d , L_q and ψ_m

-age (ψ_m) because variation in the $\Delta \hat{\psi}_{ds}$ and $\Delta \hat{\psi}_{qs}$ is very small. The variation of 20% is considered in R_s , L_d , L_q and ψ_m . It is observed from Fig.4, variation in the $\frac{\Delta \omega_r}{\Delta R_s}$, $\frac{\Delta \omega_r}{\Delta L_d}$, $\frac{\Delta \omega_r}{\Delta L_q}$ and $\frac{\Delta \omega_r}{\Delta \psi_m}$ is very small with respect to rotor speed variations.

IV. SIMULATION RESULTS

The performance of PDF-PDF controller with flux-torque based MRAS estimator for PMSM drive is simulated in the MATLAB/ SIMULINK environment. To investigate the effectiveness of proposed sensorless PMSM drive, the following test cases are considered: wide and low speed response. The parameters of the PMSM are given in Table I.

A. Wide speed variation

A wide rotor speed reference is considered to analyze the robustness of controller and estimator. The speed reference is varied between 180 to 0 rad/s, 0 to -180 rad/s and -180 to 180 rad/s at full load as shown in Fig.5. Fig. 5a shows the speed loop PI controller has overshoot of 21.6% and settling time of 150ms, whereas the speed loop PDF controller completely eliminates overshoot and has faster setting time of 75ms.

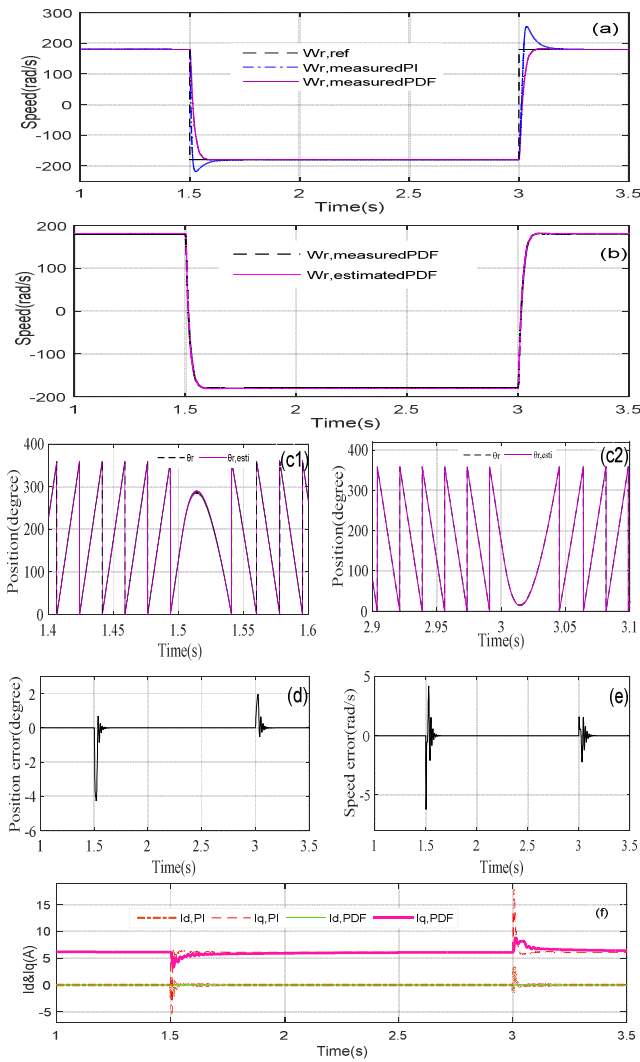

Fig. 5. Simulation results for wide speed variation
 a. reference and measured rotor speed
 b. measured and estimated rotor speed
 c1. magnified around 1.5s c2. magnified around 3s
 d. speed estimation error
 e. position estimation error and
 f. d - q axes stator current.

The estimated rotor speed follows the measured speed during speed reversal operation satisfactorily as shown in fig. 5b. The measured and estimated rotor position are shown in Fig. 5c. it is clearly seen that estimated rotor position is virtually similar to the measured rotor position. The estimated rotor speed and position error are shown in Fig.5d and e. It is observed from that, the estimated rotor position and speed error which are $\pm 4.2^\circ$ and $\pm 6\text{rad/s}$ respectively during transient condition and it is nearly zero during steady state. It is clear from the fig. 5f, stator d - q axes current has perfect decoupling at wide speed variation, during transients the stator q axes current has an overshoot of 18A (192%) with respect to nominal value of 6.12 A for current loop PI control whereas with the proposed current loop PDF controller stator q axes current shoots up to 7.5A (22.55 %) which is much smaller compared to current loop PI system.

B. Low speed variation

The sensorless rotor speed and position estimation is more challenging in low speed operation. To validate the robustness of the proposed speed and position estimator during low speed operation, different speed regions are considered at full load. Fig.6a shows the comparison of PI and PDF speed loop controller response for the low speed reference, from which it is observed that speed loop PI controller has overshoot of 19.9% and setting time of 150ms whereas speed loop PDF controller completely eliminates overshoot and has faster settling time of 75ms. The measured, estimated rotor speed (stator flux based MRAS speed estimation method and proposed estimation method) are shown in Fig. 6b. It is observed that, the proposed estimator follows actual rotor speed during low speed regions. Fig. 6c shows that, measured,

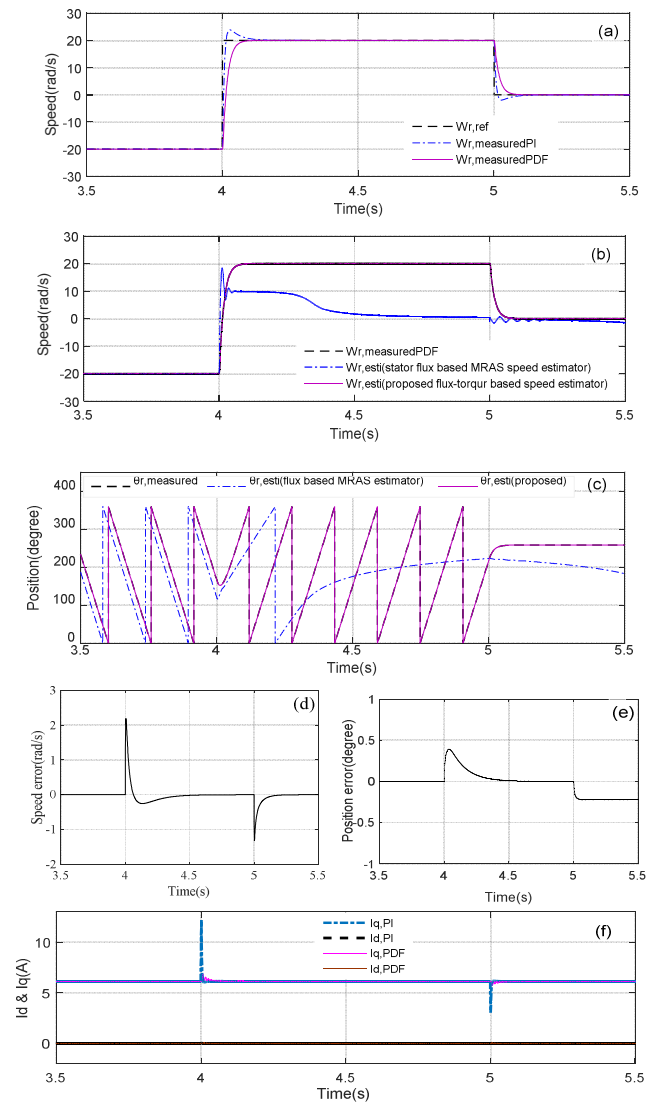

Fig. 6. Simulation results for low speed variation
 a. reference and measured rotor speed, b. measured, stator flux based MRAS estimator and proposed estimated rotor speed, c. measured, stator flux based MRAS estimator and proposed estimated rotor position d. speed estimation error, e. position estimation error and f. d - q axes stator current .

estimated rotor position (stator flux based MRAS speed estimation method and proposed estimation method). It is observed that, the proposed estimator follows the measured rotor position during low speed regions. Fig.6d and e shows that with the proposed estimator rotor speed and position error are ± 2 , $\pm 0.5^\circ$ respectively during low speed regions. From fig. 6b and c, it is clearly seen that, the performance of stator flux based MRAS speed estimator[9] is not satisfactory during low speed regions. It is observed from the fig. 6f that, though stator d - q axes current has perfect decoupling at low speed regions, during transients the stator q axes current has an overshoot of 12A (96%) with respect to nominal value of 6.12 A for current loop PI control, whereas with the proposed current loop PDF controller stator q axes current shoots up to 6.9A (7.8%) which is much smaller compared to current loop PI system.

V. EXPERIMENTAL RESULTS

The proposed pseudo derivative feedback current controlled sensorless PMSM drive with flux-torque based MRAS estimator is implemented for a 1.2 hp laboratory prototype PMSM drive using FPGA controller. The performance of proposed estimator and controller are tested over a wide adjustable speed range (± 180 rad/s) and results for low speed region is presented. The speed reversal is considered from 10 to -10 rad/s and vice versa is demonstrated in fig. 7a. It is found that during speed reversal operation, the estimated speed follows the actual speed and it has maximum speed error of around 2 rad/s. Fig. 7b demonstrates the actual and estimated position of the rotor for the proposed estimator. It is found that during speed reversal operation, the maximum position error is around 4° . Further efficacy of the proposed controller is observed from Fig. 7 a and b that the q -axes stator current has smooth transient response during speed reversal operation and d -axes stator current is maintained at zero.

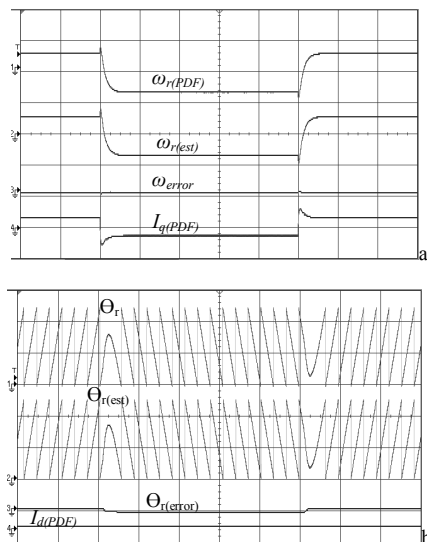

Fig. 7 Experimental results for speed reversal at low speed region (a). Measured, estimated rotor speed and rotor speed error. Scale: (ω_r (PDF), ω_r (est)=20 rad/s/div), (ω_{error} =2 rad/s/div), (i_q (PDF)=5 A/div), (T =1 s/div) (b). Measured, estimated rotor position and rotor position error. Scale: (θ_r = 150° /div), (θ_r (est)= 150° /div), (θ_{error} = 10° /div), (i_d (PDF)=1 A/div), (T =1 s/div)

VI. CONCLUSIONS

A simple and robust flux-torque based MRAS estimator and PDF-PDF controlled sensorless PMSM drive for low speed operation has been proposed in this paper. The robustness of the estimator is verified through the stability and sensitivity analysis. From these analysis it was found that, the proposed estimator performs well over a wide speed range (± 360 elec. rad/s). Further the proposed controller improves system dynamic response i.e. reduces the oscillation, overshoot and significantly improves settling time. Simulation and experimental results demonstrate the effectiveness of the proposed estimator and controller for PMSM drive during low speed regions, as well as with full load.

APPENDIX

TABLE I. PMSM RATING AND PARAMETERS

Stator: 3ph, 4 pole, 220v, 1.2 hp, 1700 rpm

Parameter	Measured value in SI units
R_s	4.2 Ω
L_d	30 mH
L_q	65 mH
λ_m	0.272 Wb
J	0.00018 kg m ²

References

- [1] Pwgasan Pillay, R. Knshnan, "Modeling of Permanent Magnet Motor Drives", *IEEE Trans. Ind. Electron.*, vol. 35, no. 4, pp. 537-541, 1988.
- [2] T.F. Chan, W. Wang, P. Borsje, Y.K. Wong, S.L. Ho, "Sensorless permanent-magnet synchronous motor drive using a reduced-order rotor flux observer", *IET Electr. Power Appl.*, vol. 2, no. 2, pp. 88–98, 2008.
- [3] Toni Tuovinen, Marko Hinkkanen, Lennart Harnfors, Jorma Luomi, "Comparison of a Reduced-Order Observer and a Full-Order Observer for Sensorless Synchronous Motor Drives", *IEEE Trans. Ind. Appl.*, vol. 48, no. 6, pp. 1959-1967, 2012.
- [4] Song Chi, Zheng Zhang, Longya Xu, "Sliding-Mode Sensorless Control of Direct-Drive PM Synchronous Motors for Washing Machine Applications", *IEEE Trans. Ind. Appl.* Vol. 45, no. 2, pp. 582-590, 2009.
- [5] Wen-Chun Chi, Ming-Yang Cheng, "Implementation of a sliding-mode-based position sensorless drive for high-speed micro permanent-magnet synchronous motors", *ISA Transactions*, vol. 53, pp. 444–453, 2014.
- [6] Yuchao Shi, Kai Sun, Lipai Huang, Yongdong Li, "Online Identification of Permanent Magnet Flux Based on Extended Kalman Filter for IPMSM Drive with Position Sensorless Control", *IEEE Trans. Ind. Electron.*, vol. 59, no. 11, pp. 4169-4178, 2012.
- [7] Yuchao Shi, Kai Sun, Lipai Huang, Yongdong Li, "Online Identification of Permanent Magnet Flux Based on Extended Kalman Filter for IPMSM Drive with Position Sensorless Control", *IEEE Trans. Ind. Electron.* Vol.59, no. 11, pp 4169-4178, 2012.
- [8] Y.S. Kim, Y.K. Choi, J.H. Lee, "Speed-sensorless vector control for permanent-magnet synchronous motors based on instantaneous reactive power in the wide-speed region", *IEE Proc.-Electr. Power Appl.* Vol. 152, no. 5, pp 1343-1349, 2005.
- [9] ZhangWenjuan, HuangShoudao, GaoJian, "Direct Torque Control for PMSM Based on Model Reference Adaptive System, in: *proceedings of International Conference on Electrical Machines and Systems*, pp. 1113-1117, 2013.
- [10] Idriss Benlaloui, Said Drid, Larbi Chrifi-Alaoui, Mohammed Ouriagli, "Implementation of a New MRAS Speed Sensorless Vector Control of Induction Machine", *IEEE Trans. Energy Conver.* Vol. 30, no. 2, pp. 588-595, 2015.
- [11] Pragasen Pillay., Ramu Krishnan.: 'Control Characteristics and Speed Controller Design for a High Performance Permanent Magnet Synchronous Motor Drive', *IEEE Trans. Power Electron.*, vol. 05, no. 2, pp 151-159 , 1990.
- [12] J. Wang., J. D. Yan., L. Jiang.: 'Pseudo-derivative-feedback current control for three-phase grid-connected inverters with LCL filters', *IEEE Trans. Power Electron.*, vol. 31, no. 5, pp 3898-3912, 2016.